



Truck Heating Solutions

Comfort and efficiency in any climate

www.cofor.us



Why choose an independent heating system?

The COFOR independent heating system ensures thermal comfort without the need to keep the engine running, optimizing fuel consumption. This translates into significant operational savings and greater autonomy in extreme weather conditions.

Key Benefits:

- Energy efficiency: Operates with low fuel consumption
- Cost savings: Eliminates unnecessary engine usage
- Stable temperature: Optimal performance in extreme climates
- Versatile installation: Adaptable to different types of vehicles



Model D4

Technical Specifications



Our systems eliminate the need to keep the engine running to heat the cabin, resulting in significant savings:

✓ Premium Quality – 2-Year Warranty

✓ **Specifications:**

- **Compatible with:** Gasoline and Diesel
- **Temperature Range:** -45°C to +40°C (-49°F to 104°F)
- **Heating Capacity:** 5 kW
- **Rated Voltage:** 12V
- **Fuel Consumption:** 0.16–0.48 L/h (0.04–0.13 gal/h)
- **Power Consumption:**
 - **Start-up:** 9–11A
 - **Operation:** 1-3A
- **Fuel Tank Capacity:** 9 L (2.38 gal)

\$855.00 USD



Installation and Compatibility



- ✓ The D4 model is compatible with a wide range of trucks and commercial vehicles, and its installation is quick and efficient.

Installation Options:

- Under the seats or in the engine compartment
- Compatible with 12V electrical systems

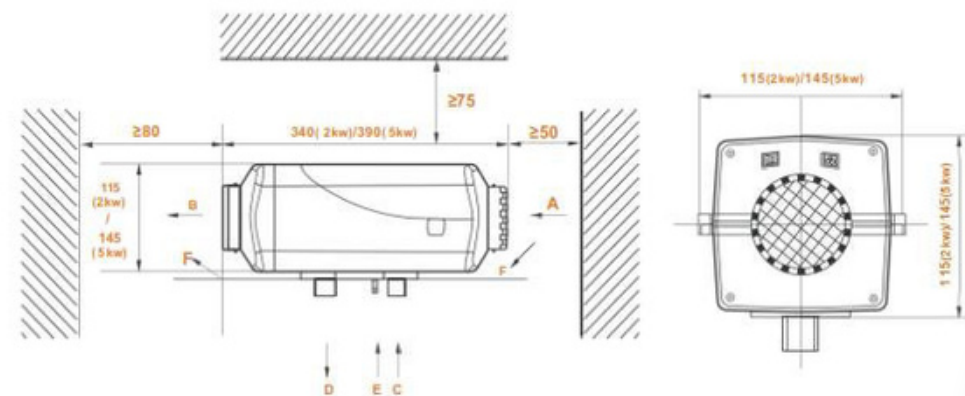
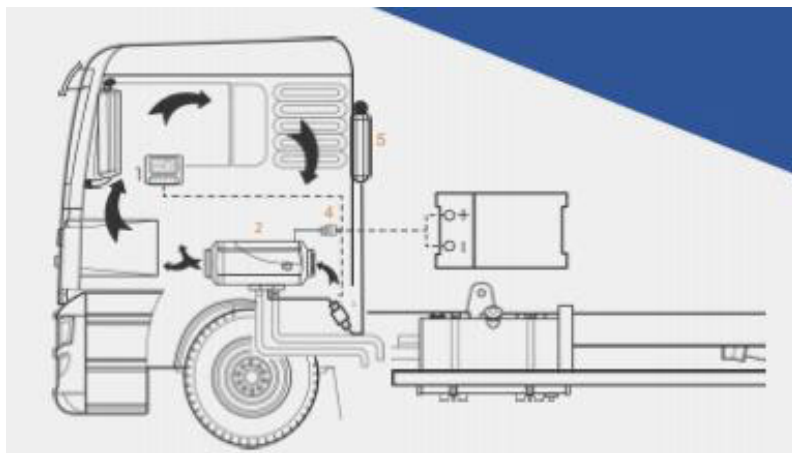

INSTALLATION DISPLAY

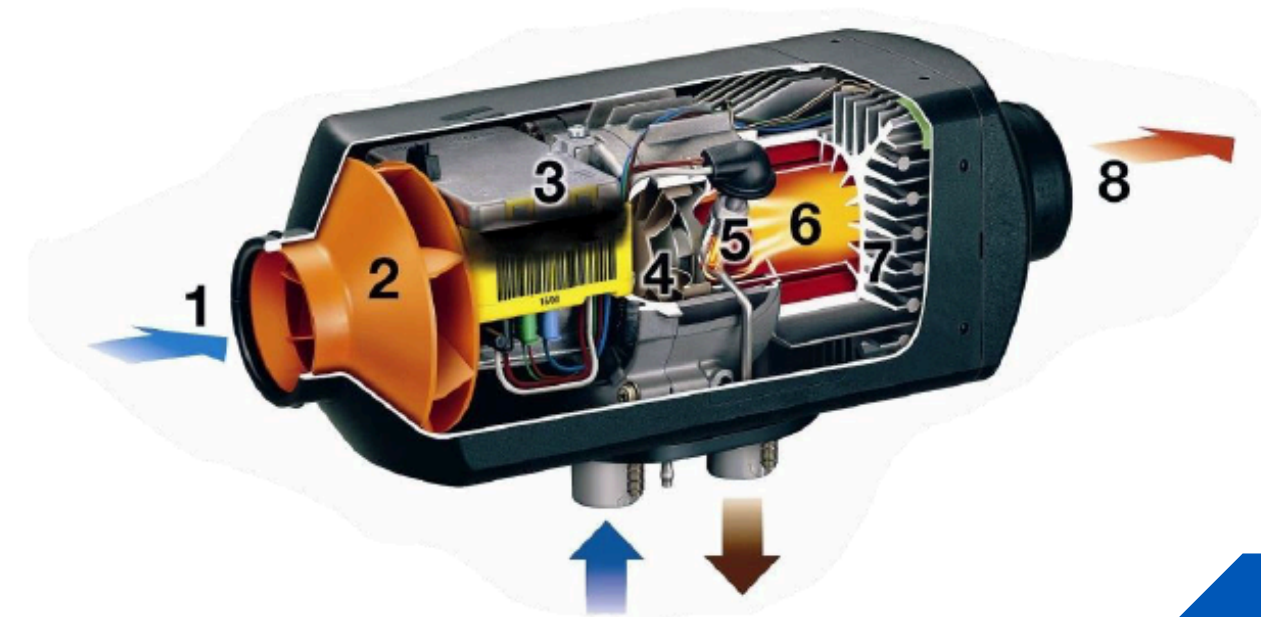
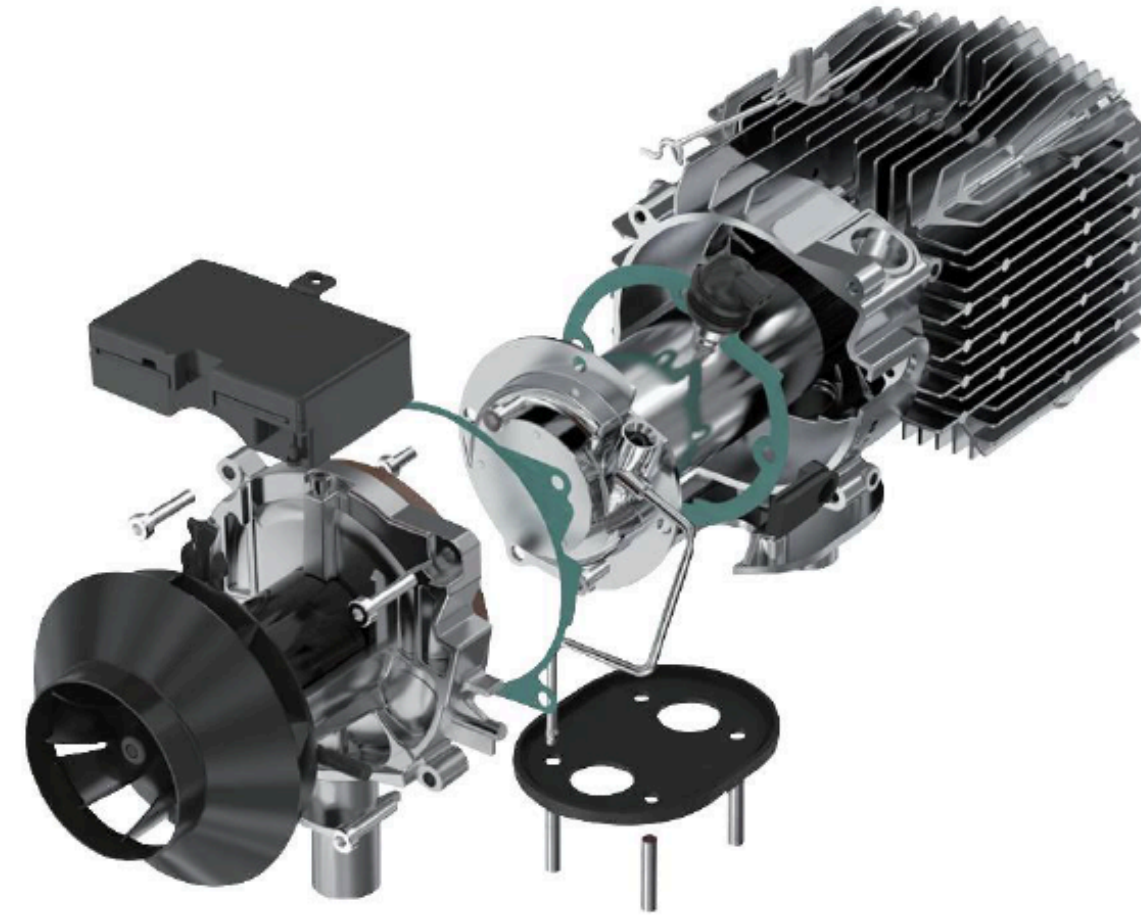
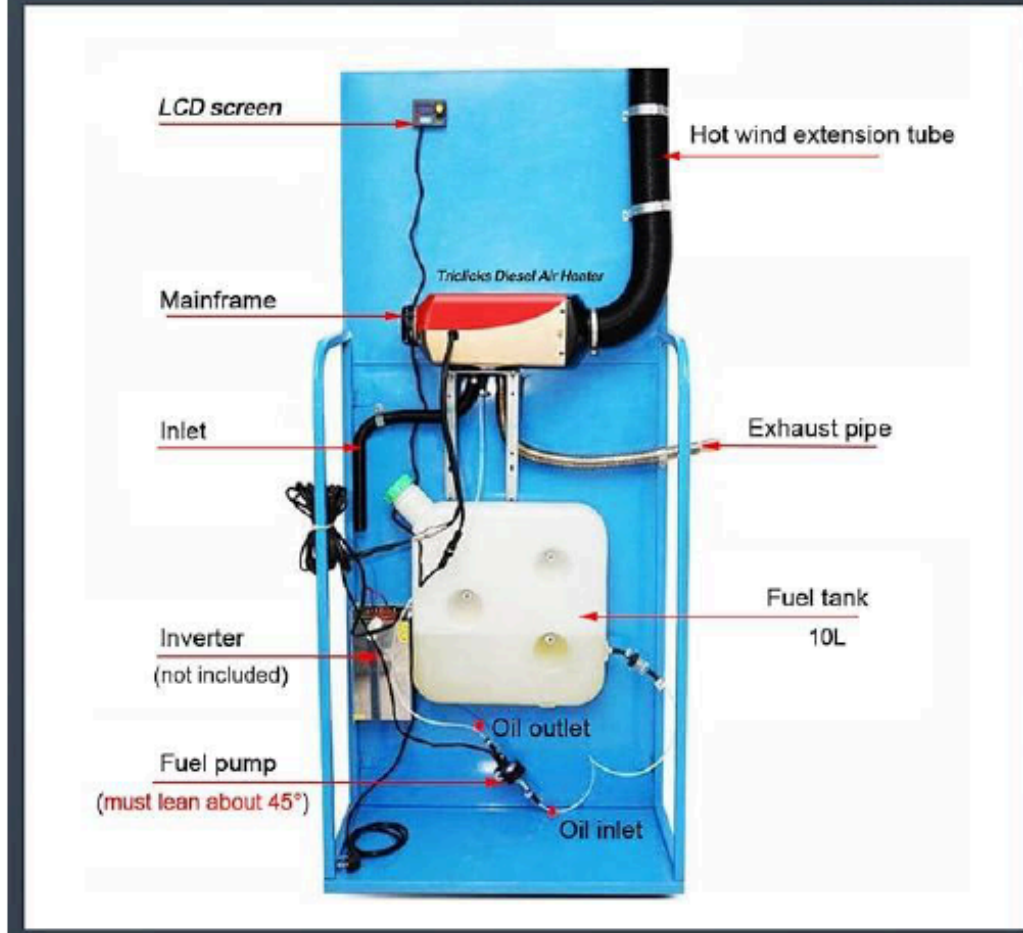



12V/24V



LCD Switch



Remote Control



Oil Pump



Silencer



Motherboard



Larynx Hoops



Wiring Harness



Tubing



Inlet / Outlet Pipes



Oil Pump Clip



Vents



Installation Kit

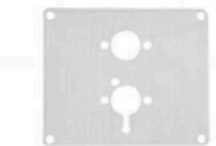

Mounting Plate



Air Filter



COFORUSA

hello@cofor.us

www.cofor.us